

**Dual N-Channel Reduced  $Q_g$ , Fast Switching MOSFET**

**Product Summary**

$V_{DS}$ (V)	$r_{DS(on)}$ ( $\Omega$ )	$I_D$ (A)
20	0.055 @ $V_{GS} = 4.5$ V	$\pm 4.5$
	0.075 @ $V_{GS} = 3.0$ V	$\pm 3.8$

**High-Efficiency**  
PWM Optimized

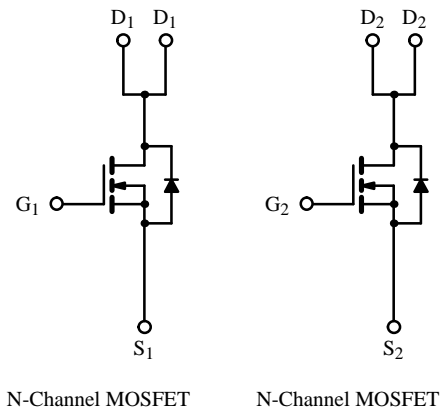
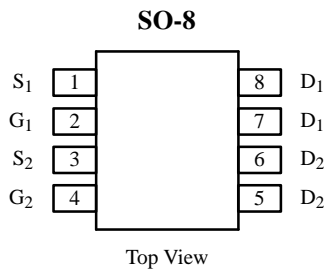

**Absolute Maximum Ratings ( $T_A = 25^\circ\text{C}$  Unless Otherwise Noted)**

Parameter	Symbol	Limit	Unit
Drain-Source Voltage	$V_{DS}$	20	V
Gate-Source Voltage	$V_{GS}$	$\pm 12$	
Continuous Drain Current ( $T_J = 150^\circ\text{C}$ ) <sup>a</sup>	$I_D$	$T_A = 25^\circ\text{C}$	$\pm 4.5$
		$T_A = 70^\circ\text{C}$	$\pm 3.6$
Pulsed Drain Current (10 $\mu\text{s}$ Pulse Width)	$I_{DM}$	$\pm 25$	A
Continuous Source Current (Diode Conduction) <sup>a</sup>	$I_S$	$\pm 1.7$	
Maximum Power Dissipation <sup>a</sup>	$P_D$	$T_A = 25^\circ\text{C}$	2
		$T_A = 70^\circ\text{C}$	1.3
Operating Junction and Storage Temperature Range	$T_J, T_{stg}$	-55 to 150	$^\circ\text{C}$

**Thermal Resistance Ratings**

Parameter	Symbol	Limit	Unit
Maximum Junction-to-Ambient <sup>a</sup>	$R_{thJA}$	62.5	$^\circ\text{C/W}$

Notes

a. Surface Mounted on FR4 Board,  $t \leq 10$  sec.

Updates to this data sheet may be obtained via facsimile by calling Siliconix FaxBack, 1-408-970-5600. Please request FaxBack document #70625.

**Specifications ( $T_J = 25^\circ\text{C}$  Unless Otherwise Noted)**

Parameter	Symbol	Test Condition	Min	Typ <sup>a</sup>	Max	Unit
<b>Static</b>						
Gate Threshold Voltage	$V_{GS(th)}$	$V_{DS} = V_{GS}, I_D = 250\ \mu\text{A}$	0.6			V
Gate-Body Leakage	$I_{GSS}$	$V_{DS} = 0\ \text{V}, V_{GS} = \pm 12\ \text{V}$			$\pm 100$	nA
Zero Gate Voltage Drain Current	$I_{DSS}$	$V_{DS} = 20\ \text{V}, V_{GS} = 0\ \text{V}$			1	$\mu\text{A}$
		$V_{DS} = 20\ \text{V}, V_{GS} = 0\ \text{V}, T_J = 70^\circ\text{C}$			5	
On-State Drain Current <sup>b</sup>	$I_{D(on)}$	$V_{DS} \geq 5\ \text{V}, V_{GS} = 5\ \text{V}$	25			A
Drain-Source On-State Resistance <sup>b</sup>	$r_{DS(on)}$	$V_{GS} = 4.5\ \text{V}, I_D = 4.5\ \text{A}$		0.044	0.055	$\Omega$
		$V_{GS} = 3.0\ \text{V}, I_D = 3.8\ \text{A}$		0.055	0.075	
Forward Transconductance <sup>b</sup>	$g_{fs}$	$V_{DS} = 10\ \text{V}, I_D = 4.5\ \text{A}$		11.5		S
Diode Forward Voltage <sup>b</sup>	$V_{SD}$	$I_S = 1.7\ \text{A}, V_{GS} = 0\ \text{V}$		0.73	1.2	V
<b>Dynamic<sup>a</sup></b>						
Total Gate Charge	$Q_g$	$V_{DS} = 10\ \text{V}, V_{GS} = 4.5\ \text{V}, I_D = 4.5\ \text{A}$		5.5	10	nC
Gate-Source Charge	$Q_{gs}$			1.2		
Gate-Drain Charge	$Q_{gd}$			1.5		
Turn-On Delay Time	$t_{d(on)}$	$V_{DD} = 10\ \text{V}, R_L = 10\ \Omega$ $I_D \cong 1\ \text{A}, V_{GEN} = 4.5\ \text{V}, R_G = 6\ \Omega$		12	25	ns
Rise Time	$t_r$			30	60	
Turn-Off Delay Time	$t_{d(off)}$			23	50	
Fall Time	$t_f$			9	20	
Source-Drain Reverse Recovery Time	$t_{rr}$	$I_F = 1.7\ \text{A}, di/dt = 100\ \text{A}/\mu\text{s}$		60	100	

## Notes

- a. Guaranteed by design, not subject to production testing.  
 b. Pulse test; pulse width  $\leq 300\ \mu\text{s}$ , duty cycle  $\leq 2\%$ .

**Typical Characteristics (25°C Unless Otherwise Noted)**

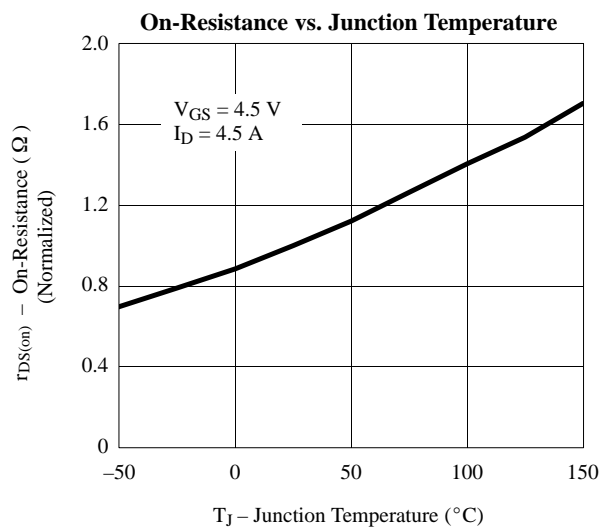
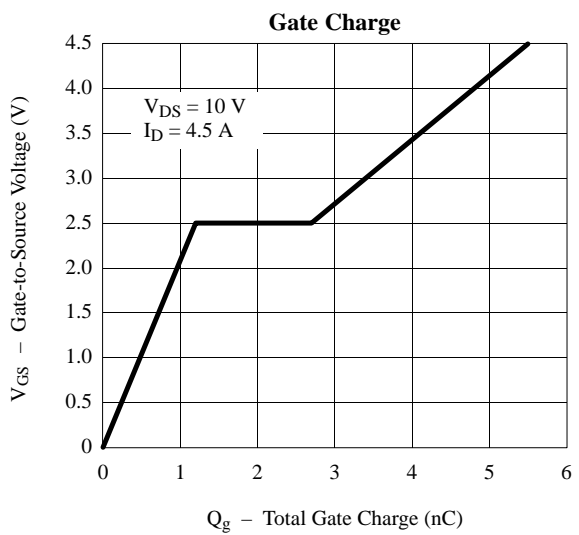
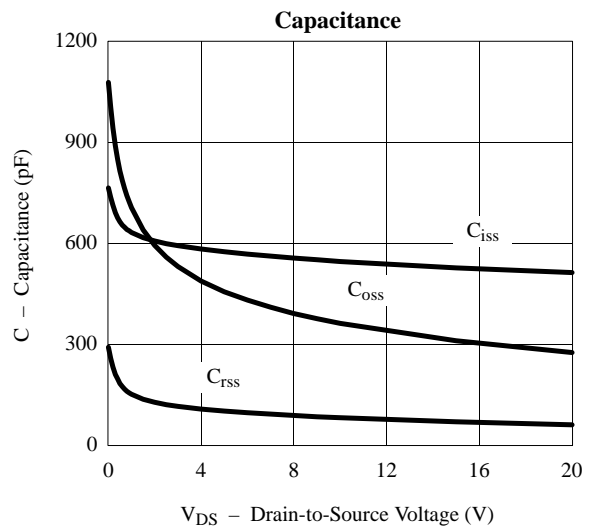
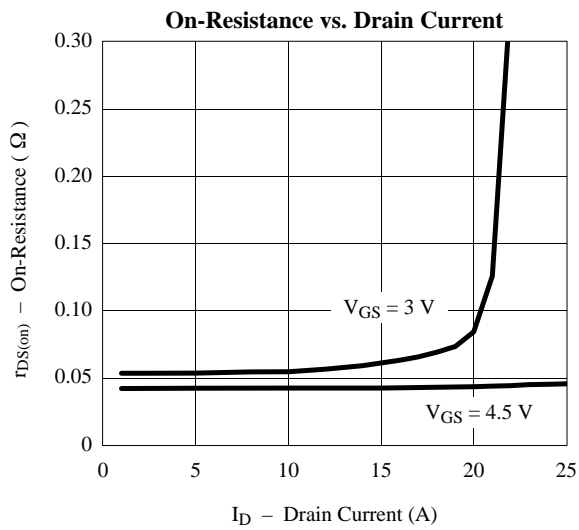
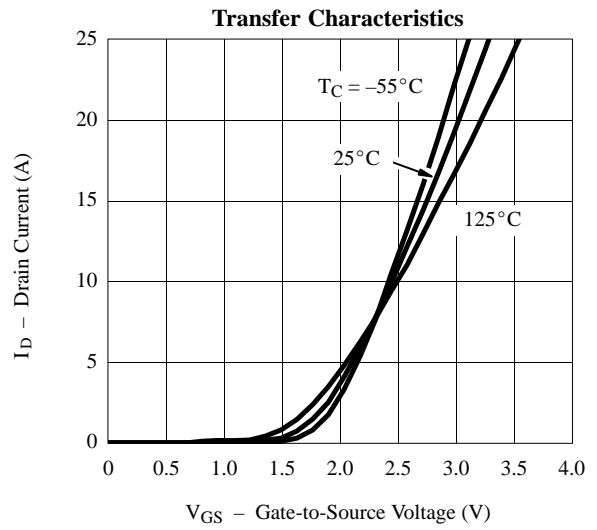
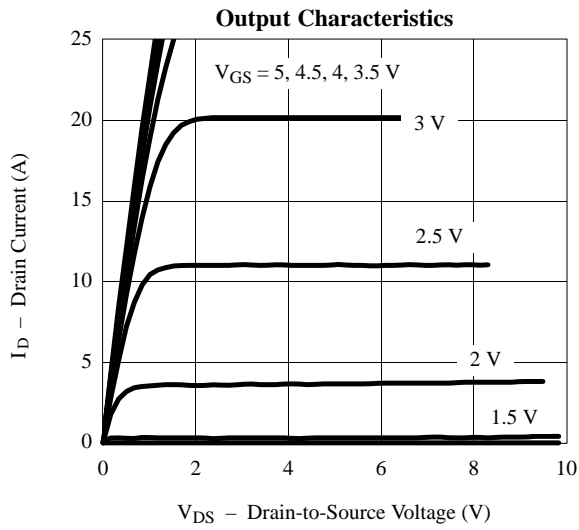

## Typical Characteristics (25°C Unless Otherwise Noted)

